

PLEASE STUDY CAREFULLY & COMPLETE ONE SHEET PER RIM

NAME _____ ADDRESS _____

TEL _____ e-mail _____

YEAR OF MANUFACTURE _____ MAKE _____ MODEL _____

RIM TYPE AND FINISH – PLEASE CHOOSE FROM THE LIST BELOW

Rolltru Premium Stainless _____ **Rolltru** Diamond British Chrome _____ **Valtru** Stainless _____ **Valtru** British Chrome _____

RIM DIAMETER _____ WIDTH WM1 (1.60") _____ WM2 (1.85") _____ WM3 (2.15") _____

(Sizes are approx. depending on manufacture & measured from inside the rim bead where your Rim Tape would sit as shown below)

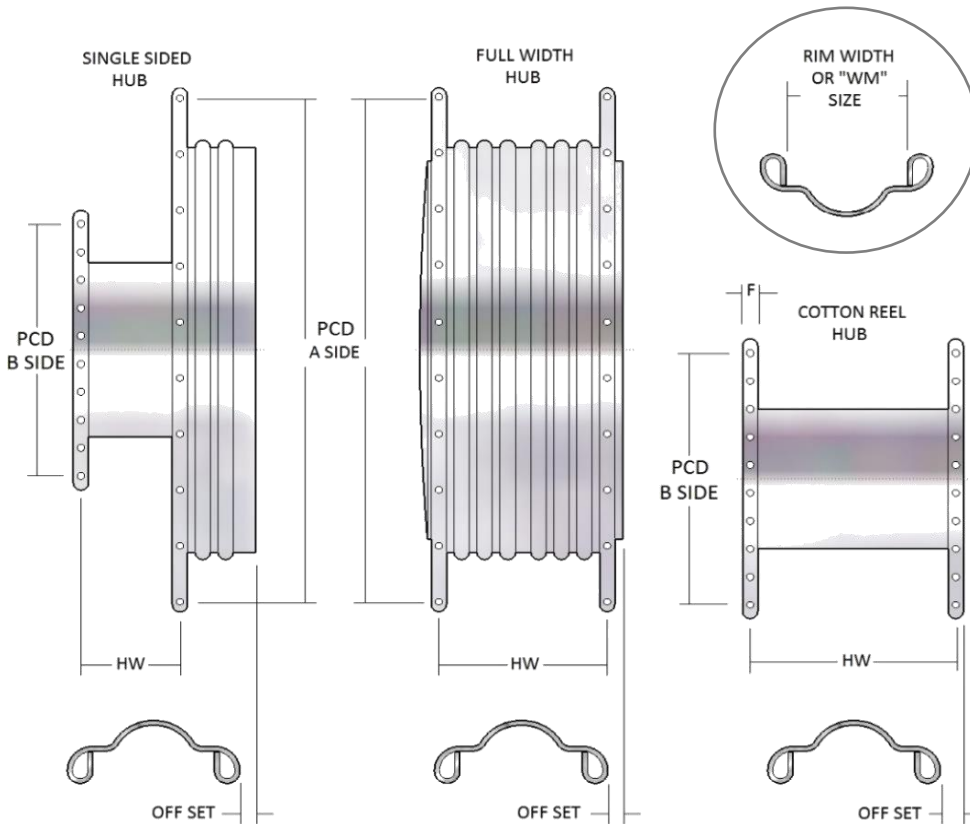

TELL US ABOUT YOUR HUB?

Please tick which of these Hub types you have.

Single Sided _____

Full Width _____

Cotton Reel _____

Are both spoke flanges the same size? _____

Side A - Are Spoke Holes – HOLES or KEY SLOTS

Side B - Are Spoke Holes – HOLES or KEY SLOTS

Please measure your Rim "Off Set". This is the distance from the edge of the Brake or Sprocket Face (Less Sprocket or Brake Plate) to the edge of your Rim as shown in the drawings here.

Off Set in Inches _____ or mm _____

This is taken from the edge of you Drum or Drive Face to the edge of your Rim

1. RIM / TYRE SIZE _____
2. No OF SPOKES _____
3. HUB WIDTH (HW) _____
4. PCD "A" Spoke hole to Spoke Hole _____
5. SPOKES CROSS "A" _____
6. PCD "B" Spoke hole to Spoke Hole _____
7. SPOKES CROSS "B" _____
8. NIPPLE HOLE SIZE _____ (this is the size of holes pierced in the rim to accept nipples, if left blank we will assume)

VERY IMPORTANT

We CANNOT manufacture without this info Spoke Crossing Pattern

This is the number of times any single spokes cross's another on the same side as itself. Pay special attention to crossings hidden under flanges.

A conventional pattern for single sided hubs might be 2 on the brake side and 3 on the other / small side. Full Width Hubs might be 2 both sides but you must check and we will use your information.

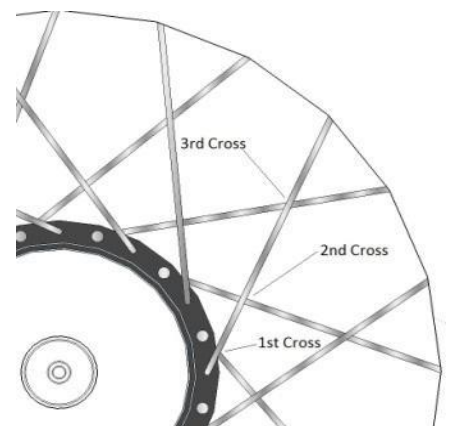

Please complete as much information as possible. If we have to guess, we cannot guarantee the quality of fitment of our products. If the information provided is found to be inaccurate this is the customers responsibility. Please take your time and if in doubt please ask.

Sorry but we cannot accept returns for any item supplied that does not fit if the information supplied on your completed sheet is supplied incorrectly.